

SORSA®

STRAPPER RAPID

AUTOMATIC STRAPPING MACHINES

5 mm

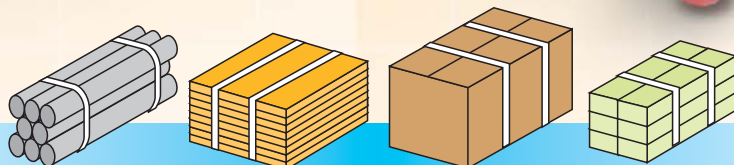

simple and reliable • for high volume applications

AUTOMATIC STRAPPING MACHINES

5 mm

**Strong and reliable technology
a perfect combination for
easy use**

STRAPPER RAPID

- Easy to use
- Operation with push buttons or foot pedal
- Reliable and secure
- For high volume applications 50 straps per minute
- 5mm strap
- Low maintenance

Simple and with its light weight easy to move about.

Electronic tension control 1-35kg / 2 levels.

Temperature and cooling time control.

Auto feeding.

Auto eject.

Auto threading in case of malfunction.

Easy and ergonomic coil change.

Complete open strap channel.

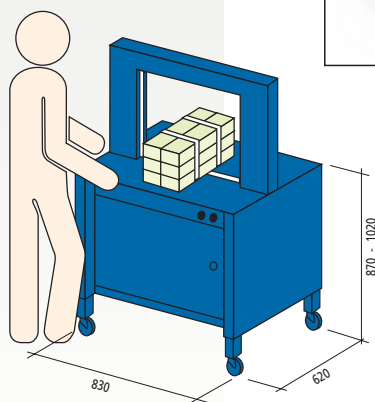

Available arch sizes

mm	650	850	1050	1250
300	★			
400		★		
500	★	★		★
600		★		
800		★	★	★
1000			★	★



STRAPPER CORRUGATE

Designed exclusively for the corrugated industry.

Top press and roller drive with variable speed.

Available arch sizes

mm	850	1250	1650
500	★	★	★

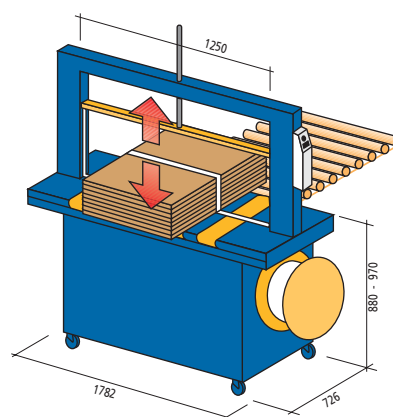

STRAPPER LINE

- Can be integrated into automated production lines

Simple and with its light weight easy to move about.

Adjustable conveyor speed (18-45m/min.).

Includes strapping position photocells.

Various strapping modes (0-1-2-3 straps).

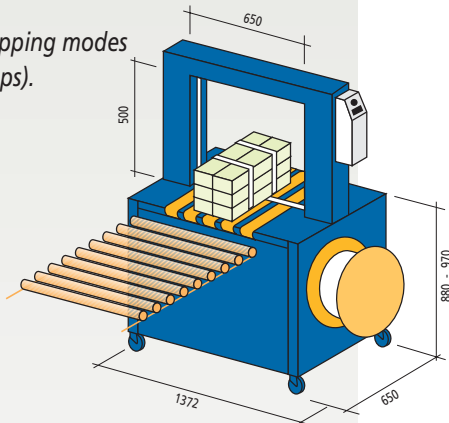

Available arch sizes				
mm	550	650	850	1050
500	★	★		
600			★	
800				★

STRAPPER PRINTING



Integrated automatic pneumatic squarer.

Pneumatic top press.

Adjustable conveyor height.

For strapping magazines, newspapers etc.

Output:

- Single strap: 35 per minute
- Double strap: 20 per minute

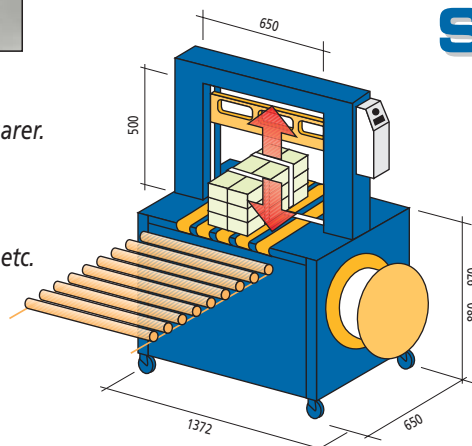

STRAPPER PICKING

Pneumatic top press for pack stability during strapping.

For light weight or fragile products.

STRAPPER RAPID

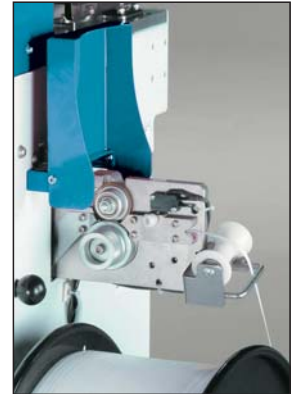
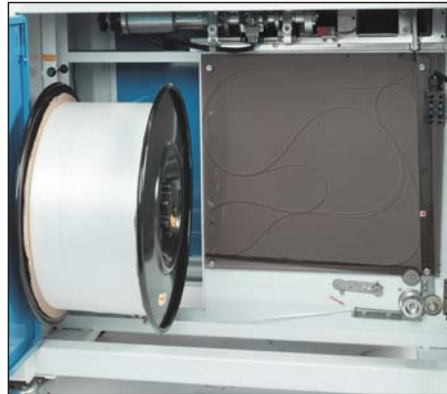
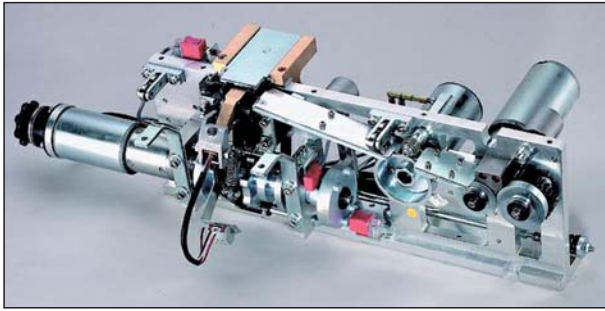

	STRAPPER RAPID	STRAPPER LINE	STRAPPER CORRUGATE	STRAPPER PICKING	STRAPPER PRINTING
Power supply	220 v II 50 Hz	220/380 v III 50 Hz	220/380 v III 50 Hz	220/380 v III 50 Hz	220/380 v III 50 Hz
Electronically adjustable strap tension	5 - 70 Kgr	5 - 70 Kgr	5 - 70 Kgr	5 - 70 Kgr	5 - 70 Kgr
Power	0,5 KW	1 KW	1 KW	1 KW	1 KW
Strap width	5 / 6 / 9 mm	5 / 6 / 9 mm	5 / 6 mm	5 / 6 mm	5 / 6 mm
Strap thickness	0,35 a 0,5 mm	0,35 a 0,55 mm	0,35 a 0,55 mm	0,35 a 0,55 mm	0,35 a 0,55 mm
Ø Strap core size	200 mm	200 mm	200 mm	200 mm	200 mm
Air consumption	—	—	10 l/cycle -6 bars	10 l/cycle -6 bars	14 l/cycle -6 bars
Table height	870 a 1020 mm	880 - 970 mm	880 - 970 mm	880 - 970 mm	880 - 970 mm
Cycle time	50 minute	35 minute	35 minute	35 minute	35 minute
Weight	150 Kgr	255 Kgr	315 Kgr	360 Kgr	400 Kgr
Type of strap: PP					
Heat seal					
Models Strapper corrugated and Strapper printing equipped with Siemens PLC					

SORSA keeps the right to make any change or modification without previous notification.

In compliance with CE standards.



SISTEMAS DE EMBALAJE SORSA S.A.

Polígono Industrial "Can Casablanças"
 C/ Anoia, 2 (corner Berguedà)
 08192 SANT QUIRZE DEL VALLÈS - Barcelona - Spain
 Tel. *34 - 93 721 40 00 - Fax 34 - 93 721 44 40
 e-mail: comer@sorsa.es - www.sorsa.es